

RPower OGiV122000L

(12V 200Ah Battery)

Floating Life at 20°C designed for 12+ years

EAN: 4260123680152

Dimensions

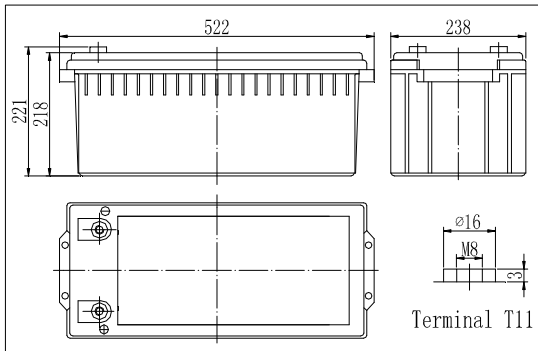

The Relationship for Open Circuit Voltage and Residual Capacity (25°C)

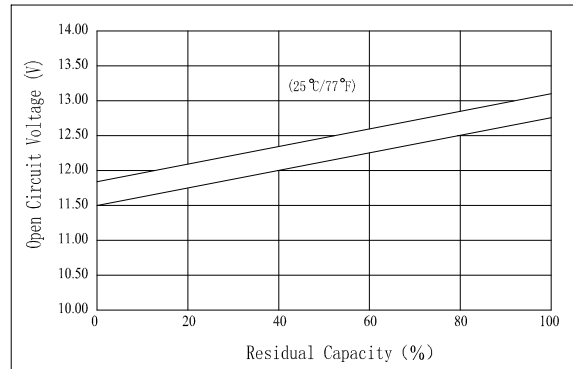

Specifications

Nominal Voltage		12V
Capacity (20hr@25°C@1.8V/C)		204Ah
Dimensions	Length	522mm (20.55inch)
	Width	238mm (9.37inch)
	Height	218mm (8.58inch)
	Total Height	221mm (8.70inch)
Approx. Weight		62.5kg (137.8lbs)
Maximum charging current		60A
Maximum discharge current		1600A (5sec.)
Internal resistance (Fully charged, 25°C)		Approx. 3mΩ
Capacity affected by temperature (10hr)	40°C	102%
	25°C	100%
	0°C	85%
	-15°C	65%
Self-discharge (25°C)	3 month	Remaining Capacity: 91%
	6 month	Remaining Capacity: 82%
	12 month	Remaining Capacity: 65%
Nominal operating temperature		25°C ±3°C (77°F±5°F)
Operating temperature range		-15°C ~ 50°C (5°F ~ 122°F)
Float charging voltage (25°C)		13.65 to 13.80V
Cyclic charging voltage (25°C)		14.50 to 14.90V
Terminal material		Copper

Charging Characteristics (25°C)

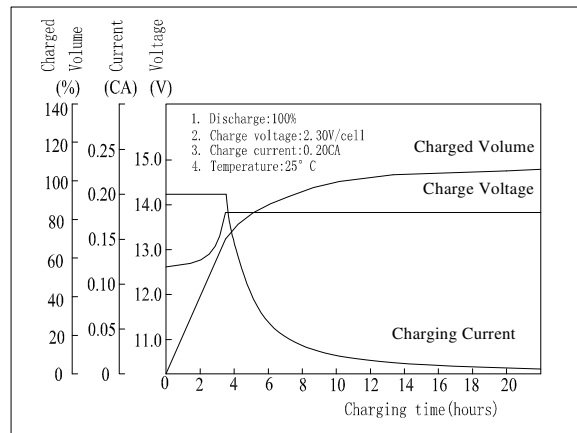

Cycle Life (25°C)

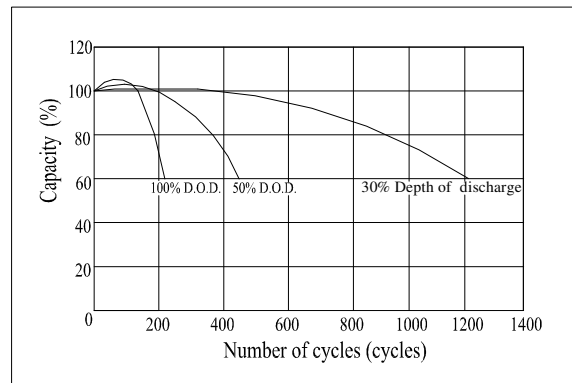

Constant Current Discharge Characteristics (Ampere / Battery, 25°C)

F.V/TIME	5min	10min	15min	30min	1h	3h	5h	10h	20h
9.60V	650	430	370	210	130	55,0	38,2	20,3	10,4
10.2V	618	409	355	202	125	53,5	37,0	20,1	10,3
10.8V	580	384	337	192	119	52,4	36,3	20,0	10,2

Constant Power Discharge Characteristics (Watt / Battery, 25°C)

F.V/TIME	5min	10min	15min	30min	1h	3h	5h	10h	20h
9.60V	6825	4644	4063	2356	1482	639	444	242	124
10.2V	6484	4421	3900	2262	1425	629	437	241	123
10.8V	6095	4147	3705	2149	1352	617	429	240	122

Valid from 12-2014