

RPower OGiV121100L (12V 110Ah Battery)

Floating Life at 20°C designed for 12+ years

EAN: 4260123680664

Dimensions

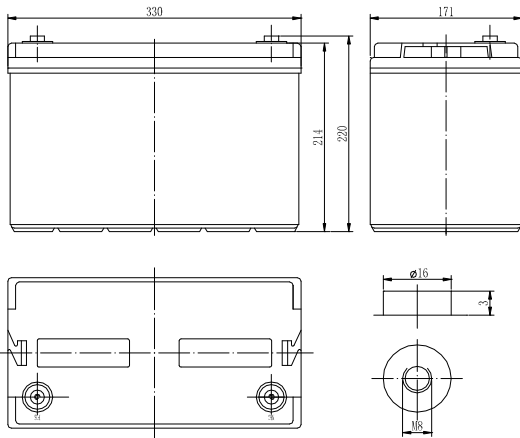

The Relationship for Open Circuit Voltage and Residual Capacity (25°C)

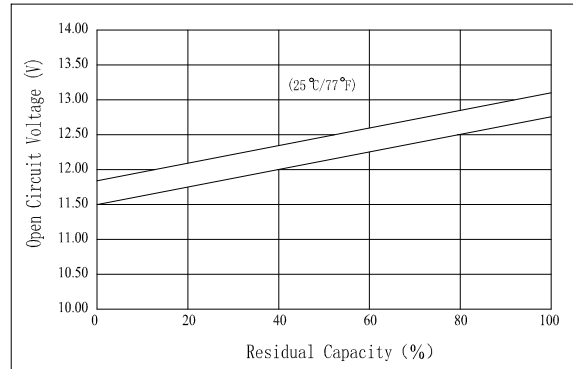

Specifications

Nominal Voltage		12V
Capacity (20hr@25°C@1.8V/C)		115.6Ah
Dimensions	Length	330mm (12.99inch)
	Width	171mm (6.73inch)
	Height	214mm (8.43inch)
	Total Height	220mm (8.66inch)
Approx. Weight		32.5kg (71.7lbs)
Maximum charging current		36A
Maximum discharge current		880A (5sec.)
Internal resistance (Fully charged, 25°C)		Approx. 4mΩ
Capacity affected by temperature (10hr)	40°C	102%
	25°C	100%
	0°C	85%
	-15°C	65%
Self-discharge (25°C)	3 month	Remaining Capacity: 91%
	6 month	Remaining Capacity: 82%
	12 month	Remaining Capacity: 65%
Nominal operating temperature		25°C ±3°C (77°F±5°F)
Operating temperature range		-15°C ~ 50°C (5°F ~ 122°F)
Float charging voltage (25°C)		13.65 to 13.80V
Cyclic charging voltage (25°C)		14.50 to 14.90V
Terminal material		Copper

Charging Characteristics (25°C)

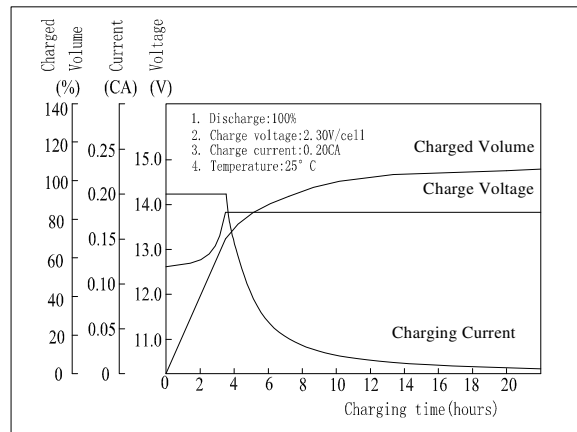

Cycle Life (25°C)

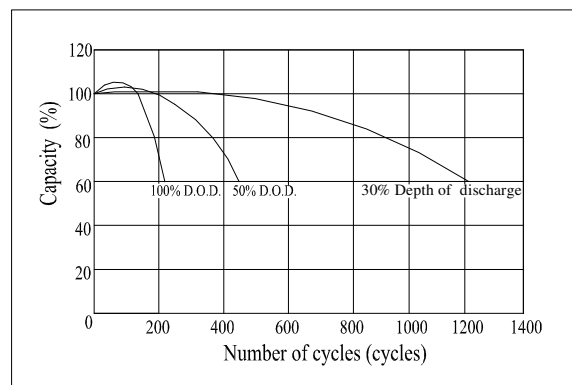

Constant Current Discharge Characteristics (Ampere / Battery, 25°C)

F.V./TIME	5min	10min	15min	30min	1h	3h	5h	10h	20h
9.60V	347	231	182	114	69,3	28,5	20,1	11,2	5,86
10.2V	329	219	174	110	66,5	28,1	19,8	11,1	5,81
10.8V	309	206	166	104	63,2	27,5	19,4	11,0	5,78

Constant Power Discharge Characteristics (Watt / Battery, 25°C)

F.V./TIME	5min	10min	15min	30min	1h	3h	5h	10h	20h
9.60V	3638	2495	1993	1284	790	335	238	133	70,3
10.2V	3456	2370	1913	1232	758	330	234	132	69,7
10.8V	3249	2228	1817	1171	720	323	229	132	69,3