

RPower OGiV12650L (12V 65Ah Battery)

Floating Life at 20°C designed for 12+ years

EAN: 4260123680091

Dimensions

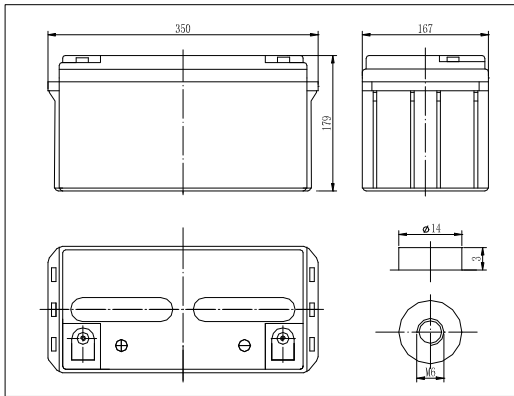

The Relationship for Open Circuit Voltage and Residual Capacity (25°C)

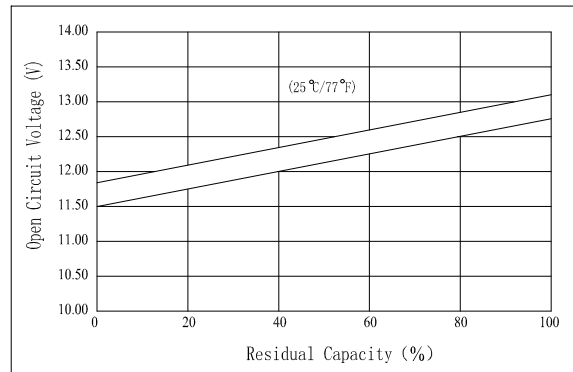

Specifications

Nominal Voltage	12V	
Capacity (20hr@25°C@1.8V/C)	68Ah	
Dimensions	Length	350mm (13.78inch)
	Width	167mm (6.57inch)
	Height	179mm (7.05inch)
	Total Height	179mm (7.05inch)
Approx. Weight	21.2kg (46.6lbs)	
Maximum charging current	19.5A	
Maximum discharge current	650A (5sec.)	
Internal resistance (Fully charged, 25°C)	Approx. 6mΩ	
Capacity affected by temperature (10hr)	40°C	102%
	25°C	100%
	0°C	85%
	-15°C	65%
Self-discharge (25°C)	3 month	Remaining Capacity: 91%
	6 month	Remaining Capacity: 82%
	12 month	Remaining Capacity: 65%
Nominal operating temperature	25°C ±3°C (77°F±5°F)	
Operating temperature range	-15°C ~ 50°C (5°F ~ 122°F)	
Float charging voltage (25°C)	13.65 to 13.80V	
Cyclic charging voltage (25°C)	14.50 to 14.90V	
Terminal material	Copper	

Charging Characteristics (25°C)

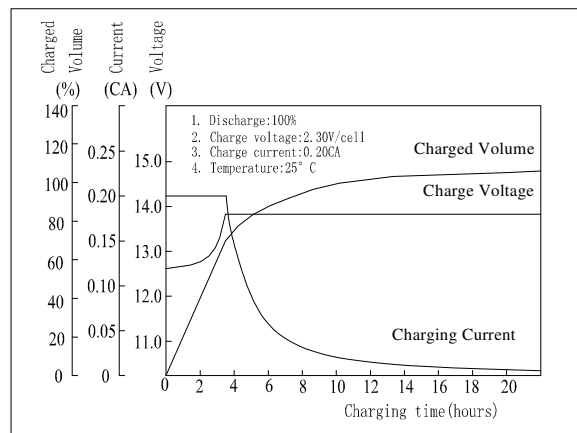

Cycle Life (25°C)

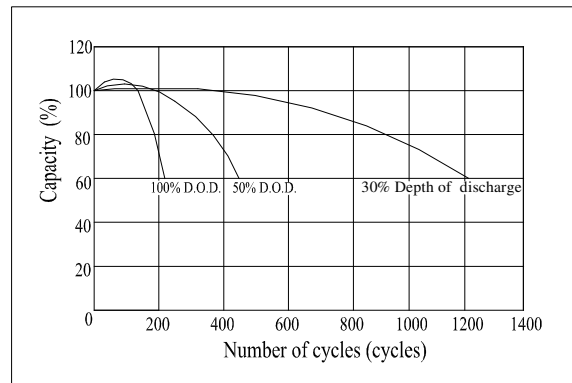

Constant Current Discharge Characteristics (Ampere / Battery, 25°C)

F.V/TIME	5min	10min	15min	30min	1h	3h	5h	10h	20h
9.60V	205	143	110	67,0	41,0	16,7	11,7	6,65	3,45
10.2V	195	136	106	64,3	39,4	16,5	11,5	6,60	3,45
10.8V	183	128	100	61,1	37,4	16,2	11,3	6,50	3,40

Constant Power Discharge Characteristics (Watt / Battery, 25°C)

F.V/TIME	5min	10min	15min	30min	1h	3h	5h	10h	20h
9.60V	2153	1544	1208	752	467	196	138	79,4	41,4
10.2V	2045	1467	1159	722	449	194	136	78,8	41,4
10.8V	1922	1379	1102	686	426	191	134	77,6	40,8

Valid from 12-2014