

RPower OGiV12400L (12V 40Ah Battery)

Floating Life at 20°C designed for 12+ years

EAN: 4260123680060

Dimensions

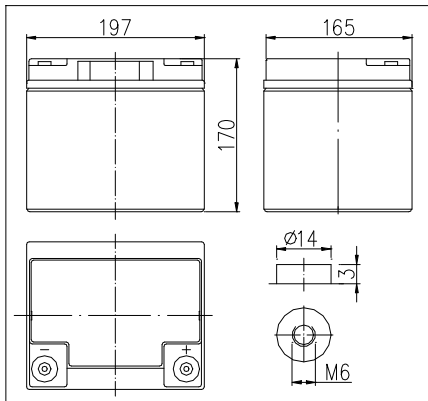

The Relationship for Open Circuit Voltage and Residual Capacity (25°C)

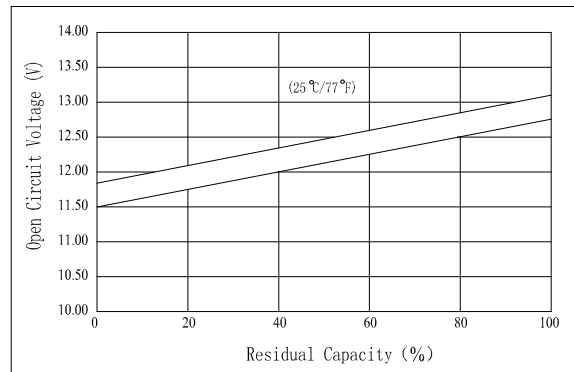

Specifications

Nominal Voltage		12V
Capacity (20hr@25°C@1.8V/C)		41Ah
Dimensions	Length	197mm (7.76inch)
	Width	165mm (6.50inch)
	Height	170mm (6.69inch)
	Total Height	170mm (6.69inch)
Approx. Weight		13.3kg (29.3lbs)
Maximum charging current		12A
Maximum discharge current		400A (5sec.)
Internal resistance (Fully charged, 25°C)		Approx. 9.5mΩ
Capacity affected by temperature (10hr)	40°C	102%
	25°C	100%
	0°C	85%
	-15°C	65%
Self-discharge (25°C)	3 month	Remaining Capacity: 91%
	6 month	Remaining Capacity: 82%
	12 month	Remaining Capacity: 65%
Nominal operating temperature		25°C ±3°C (77°F±5°F)
Operating temperature range		-15°C ~ 50°C (5°F ~ 122°F)
Float charging voltage (25°C)		13.65 to 13.80V
Cyclic charging voltage (25°C)		14.50 to 14.90V
Terminal material		Copper

Charging Characteristics (25°C)

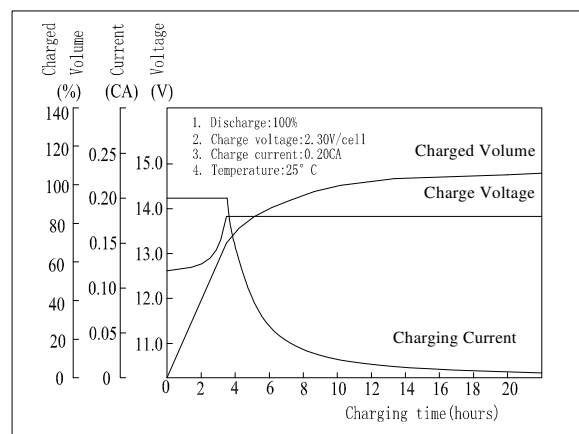

Cycle Life (25°C)

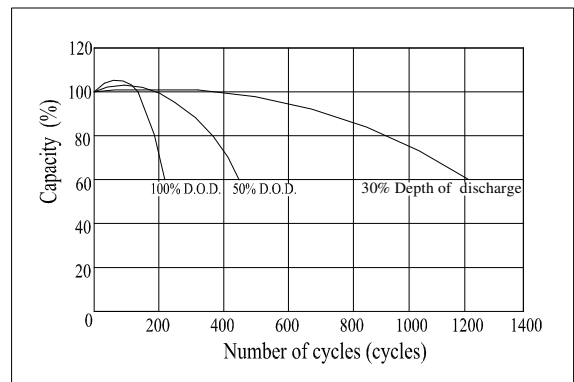

Constant Current Discharge Characteristics (Ampere / Battery, 25°C)

F.V/TIME	5min	10min	15min	30min	1h	3h	5h	10h	20h
9.60V	122	81,0	68,0	40,0	26,0	10,4	7,31	4,06	2,10
10.2V	116	77,0	65,3	38,4	25,0	10,2	7,20	4,02	2,10
10.8V	109	72,3	62,0	36,5	23,7	10,0	7,06	4,00	2,05

Constant Power Discharge Characteristics (Watt / Battery, 25°C)

F.V/TIME	5min	10min	15min	30min	1h	3h	5h	10h	20h
9.60V	1281	875	747	449	296	122	86,4	48,5	25,2
10.2V	1217	831	717	431	285	120	85,1	48,0	25,2
10.8V	1144	781	681	409	270	118	83,4	48,0	24,6

Valid from 12-2014