

RPower OGiV12280L

(12V 28Ah Battery)

Floating Life at 20°C designed for 12+ years

EAN: 4260123680046

Dimensions

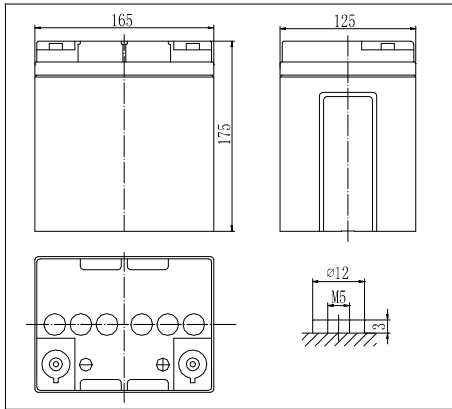

The Relationship for Open Circuit Voltage and Residual Capacity (25°C)

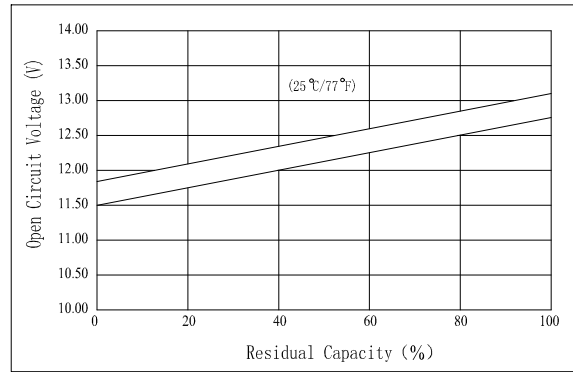

Specifications

Nominal Voltage		12V
Capacity (20hr@25°C@1.8V/C)		28Ah
Dimensions	Length	165mm (6.50inch)
	Width	125mm (4.92inch)
	Height	175mm (6.89inch)
	Total Height	175mm (6.89inch)
Approx. Weight		9.5kg (20.9lbs)
Maximum charging current		8.4A
Maximum discharge current		420A (5sec.)
Internal resistance (Fully charged, 25°C)		Approx. 11mΩ
Capacity affected by temperature (20hr)	40°C	102%
	25°C	100%
	0°C	85%
	-15°C	65%
Self-discharge (25°C)	3 month	Remaining Capacity: 91%
	6 month	Remaining Capacity: 82%
	12 month	Remaining Capacity: 65%
Nominal operating temperature		25°C ±3°C (77°F±5°F)
Operating temperature range		-15°C ~ 50°C (5°F ~ 122°F)
Float charging voltage (25°C)		13.65 to 13.80V
Cyclic charging voltage (25°C)		14.50 to 14.90V
Terminal material		Copper

Charging Characteristics (25°C)

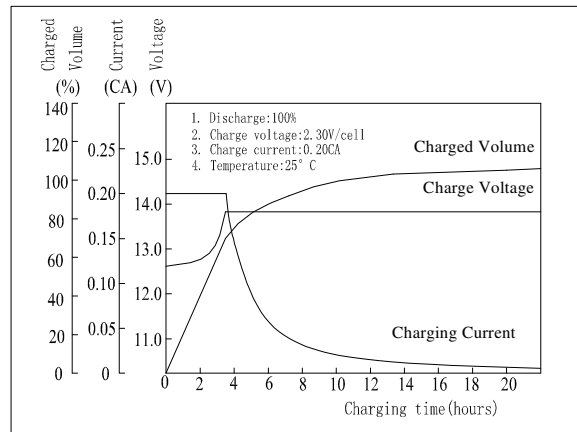

Cycle Life (25°C)

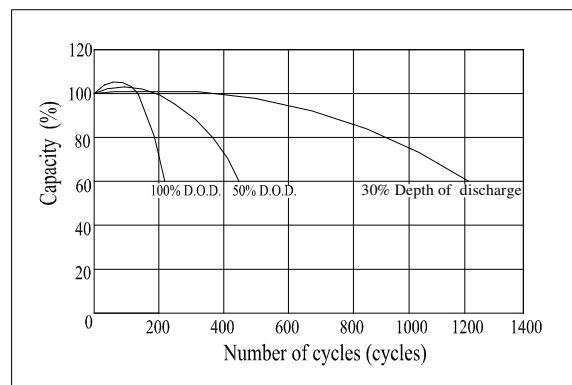

Constant Current Discharge Characteristics (Ampere / Battery, 25°C)

F.V./TIME	5min	10min	15min	30min	1h	3h	5h	10h	20h
9.60V	106	67,2	53,2	30,8	18,2	7,11	4,83	2,61	1,42
10.2V	99,0	63,8	50,5	29,6	17,5	7,00	4,76	2,60	1,41
10.8V	89,4	60,0	47,5	28,1	16,6	6,72	4,57	2,58	1,40

Constant Power Discharge Characteristics (Watt / Battery, 25°C)

F.V./TIME	5min	10min	15min	30min	1h	3h	5h	10h	20h
9.60V	1145	758	606	353	211	84,4	57,7	31,4	17,1
10.2V	1065	720	576	339	202	83,2	56,8	31,2	17,0
10.8V	962	677	542	322	192	79,8	54,6	30,9	16,8

Valid from 12-2014