

RPower OGiV12170L (12V 17Ah Battery)

Floating Life at 20°C designed for 12+ years

EAN: 4260123680039

Dimensions

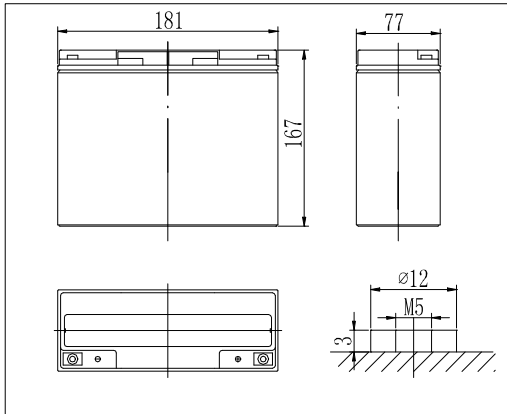

The Relationship for Open Circuit Voltage and Residual Capacity (25°C)

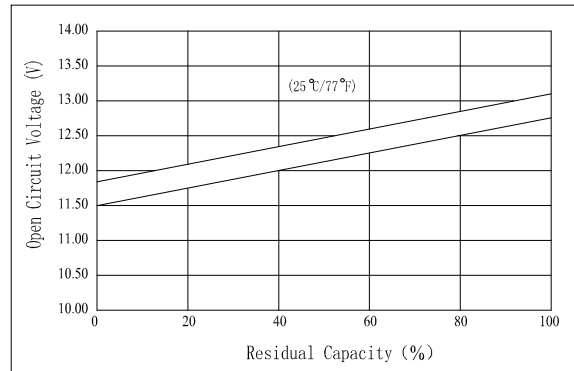

Specifications

Nominal Voltage		12V
Capacity (20hr@25°C@1.8V/C)		17Ah
Dimensions	Length	181mm (7.13inch)
	Width	77mm (3.03inch)
	Height	167mm (6.57inch)
	Total Height	167mm (6.57inch)
Approx. Weight		5.5kg (12.1lbs)
Maximum charging current		5.1A
Maximum discharge current		255A (5sec.)
Internal resistance (Fully charged, 25°C)		Approx. 17mΩ
Capacity affected by temperature (20hr)	40°C	102%
	25°C	100%
	0°C	85%
	-15°C	65%
Self-discharge (25°C)	3 month	Remaining Capacity: 91%
	6 month	Remaining Capacity: 82%
	12 month	Remaining Capacity: 65%
Nominal operating temperature		25°C ±3°C (77°F±5°F)
Operating temperature range		-15°C ~ 50°C (5°F ~ 122°F)
Float charging voltage (25°C)		13.65 to 13.80V
Cyclic charging voltage (25°C)		14.50 to 14.90V
Terminal material		Copper

Charging Characteristics (25°C)

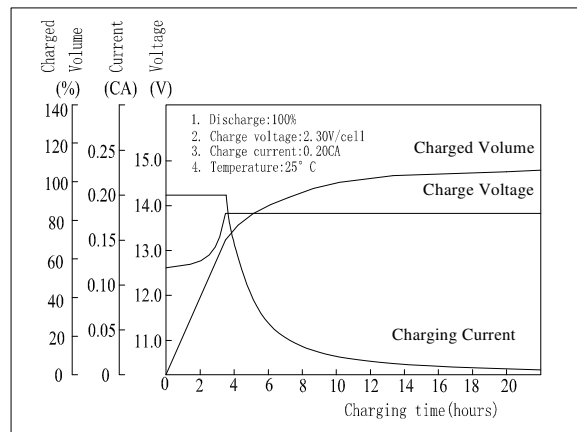

Cycle Life (25°C)

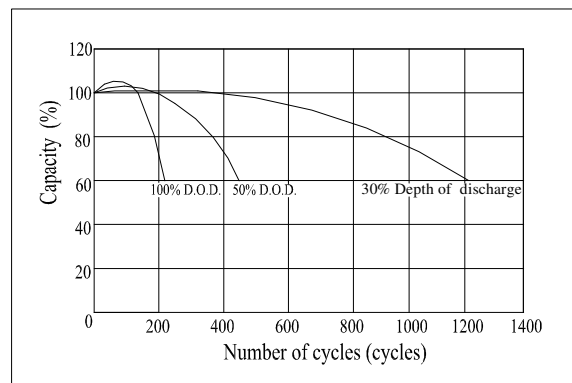

Constant Current Discharge Characteristics (Ampere / Battery, 25°C)

F.V./TIME	5min	10min	15min	30min	1h	3h	5h	10h	20h
9.60V	61,6	38,9	31,1	18,0	10,8	4,31	2,93	1,59	0,86
10.2V	58,5	36,9	29,9	17,3	10,4	4,25	2,89	1,58	0,86
10.8V	55,0	34,7	28,4	16,4	9,85	4,08	2,77	1,56	0,85

Constant Power Discharge Characteristics (Watt / Battery, 25°C)

F.V./TIME	5min	10min	15min	30min	1h	3h	5h	10h	20h
9.60V	687	439	354	206	125	51,2	35,0	19,0	10,4
10.2V	653	417	340	198	120	50,5	34,5	19,0	10,3
10.8V	613	392	323	188	114	48,5	33,1	18,8	10,2

Valid from 12-2014