

GELOGiV121350L (12V 135Ah GEL Battery)

Floating Life at 20°C designed for 12+ years

EAN: 4260123683399

Dimensions

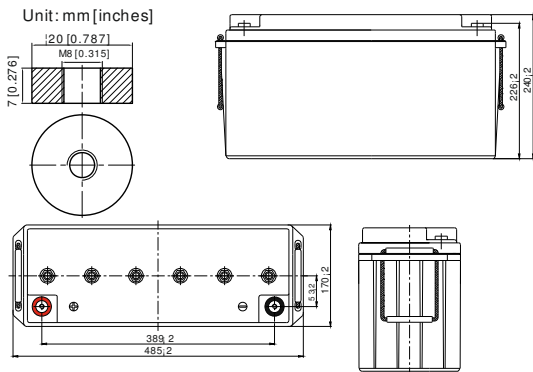

Temperature Effects in Relation to Battery Capacity

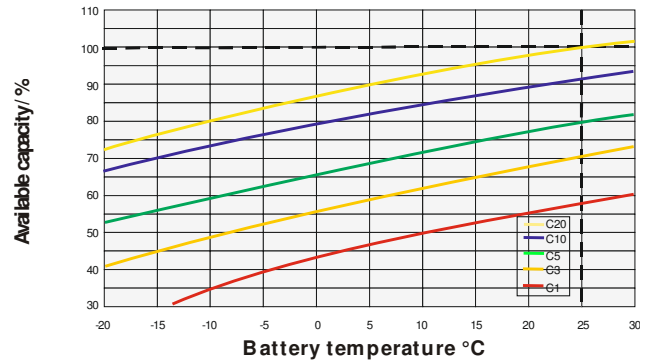

Specifications

Nominal Voltage		12V
Capacity (25°C@1.8V/C)		C20: 135Ah C5: 104Ah
Dimensions	Length	485mm (19.09inch)
	Width	170mm (6.69inch)
	Height	240mm (9.45inch)
	Total Height	240mm (9.45inch)
Approx. Weight		47.2kg (104.1lbs)
Maximum charging current		40.5A
Maximum discharge current		1260A (5sec.)
Internal resistance		Approx. 4.5mΩ
Capacity affected by temperature (20hr)	40°C	103%
	25°C	100%
	0°C	86%
	-15°C	65%
Self-discharge (25°C)	3 month	Remaining Capacity: 91%
	6 month	Remaining Capacity: 82%
	12 month	Remaining Capacity: 65%
Nominal operating temperature		25°C ±3°C (77°F±5°F)
Operating temperature range		-20°C ~ 55°C (-4°F ~ 131°F)
Float charging voltage (25°C)		13.65 to 13.80V
Cyclic charging voltage (25°C)		14.40 to 15.00V
Terminal material		Copper

Float Charging Characteristics

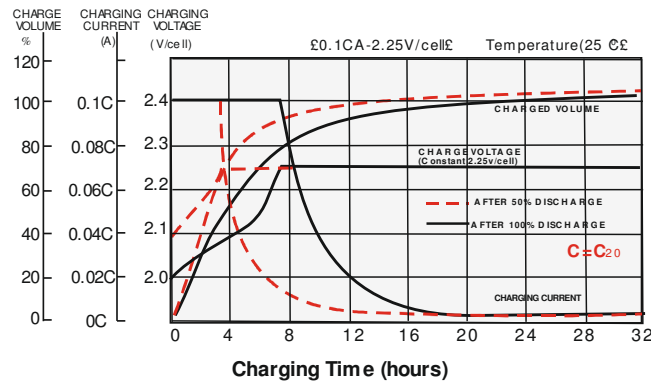

Cycle Life in Relation to Depth of Discharge

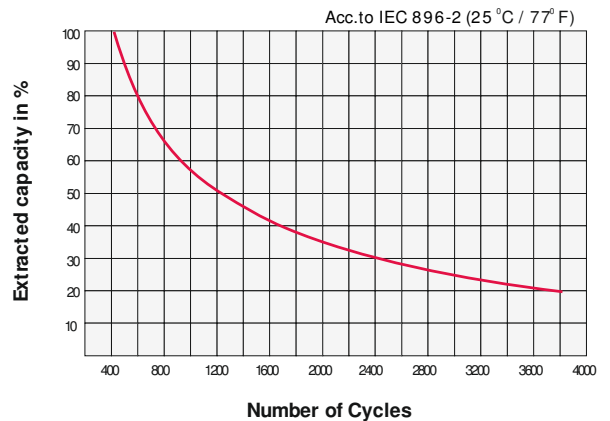

Constant Current Discharge Characteristics (Ampere / Cell, 25°C)

F.V/TIME	20min	30min	45min	1h	3h	5h	8h	10h	20h
1.60V/cell	178,6	131,2	96,3	78,8	35,0	23,4	15,7	13,3	7,14
1.70V/cell	158,4	118,0	86,6	71,6	32,6	22,3	15,2	12,9	6,97
1.80V/cell	130,8	100,2	75,4	63,2	29,7	20,8	14,3	12,3	6,75

Constant Power Discharge Characteristics (Watt / Cell, 25°C)

F.V/TIME	20min	30min	45min	1h	3h	5h	8h	10h	20h
1.60V/cell	322,7	241,2	180,1	149,4	67,4	45,6	30,9	26,3	14,2
1.70V/cell	292,6	221,2	164,2	137,1	63,4	43,6	30,0	25,5	13,9
1.80V/cell	247,1	191,2	145,2	122,4	57,9	40,9	28,4	24,5	13,5

Valid from 12-2014