

# GELOGiV121100L (12V 110Ah GEL Battery)

Floating Life at 20°C designed for 12+ years

EAN: 4260123683382

## Dimensions

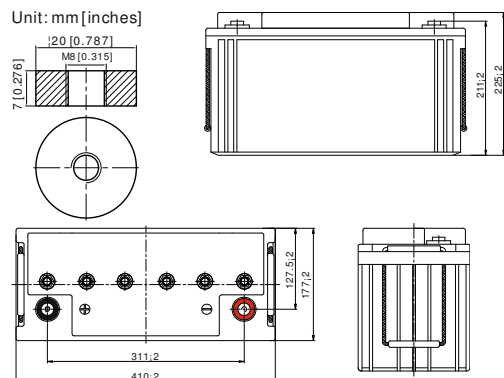

## Specifications

Nominal Voltage		12V
Capacity (25°C@1.8V/C)		C20: 110Ah C5: 84.5Ah
Dimensions	Length	410mm (16.14inch)
	Width	177mm (6.97inch)
	Height	225mm (8.86inch)
	Total Height	225mm (8.86inch)
Approx. Weight		36.0kg (79.38lbs)
Maximum charging current		33.0A
Maximum discharge current		990A (5sec.)
Internal resistance		Approx. 5.1mΩ
Capacity affected by temperature (20hr)	40°C	103%
	25°C	100%
	0°C	86%
	-15°C	65%
Self-discharge (25°C)	3 month	Remaining Capacity: 91%
	6 month	Remaining Capacity: 82%
	12 month	Remaining Capacity: 65%
Nominal operating temperature		25°C ±3°C (77°F±5°F)
Operating temperature range		-20°C ~ 55°C (-4°F ~ 131°F)
Float charging voltage (25°C)		13.65 to 13.80V
Cyclic charging voltage (25°C)		14.40 to 15.00V
Terminal material		Copper

## Temperature Effects in Relation to Battery Capacity

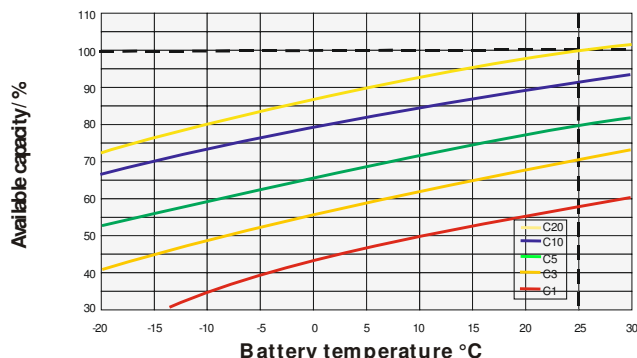

## Float Charging Characteristics

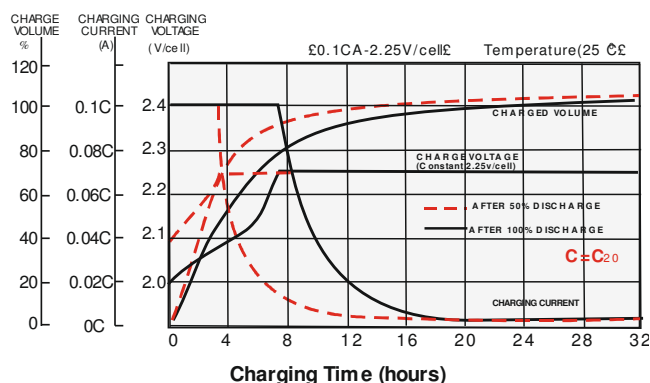

## Cycle Life in Relation to Depth of Discharge

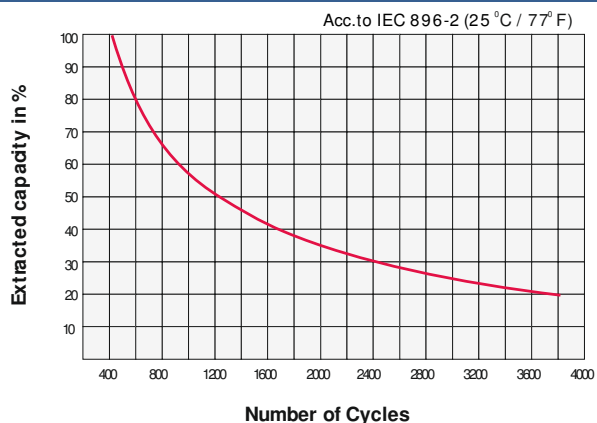

## Constant Current Discharge Characteristics (Ampere / Cell, 25°C)

F. V/TIME	20min	30min	45min	1h	3h	5h	8h	10h	20h
1.60V/cell	145,5	106,9	78,5	64,2	28,5	19,1	12,8	10,8	5,82
1.70V/cell	129,0	96,1	70,5	58,3	26,6	18,2	12,4	10,5	5,68
1.80V/cell	106,6	81,6	61,5	51,5	24,2	16,9	11,6	10,0	5,50

## Constant Power Discharge Characteristics (Watt / Cell, 25°C)

F. V/TIME	20min	30min	45min	1h	3h	5h	8h	10h	20h
1.60V/cell	263,0	196,5	146,7	121,7	54,9	37,1	25,2	21,4	11,5
1.70V/cell	238,4	180,3	133,8	111,7	51,6	35,5	24,5	20,8	11,3
1.80V/cell	201,3	155,8	118,3	99,7	47,2	33,3	23,1	20,0	11,0

Valid from 12-2014