

# GELOGiV12900L SOLAR (12V 90Ah GEL Battery)

Floating Life at 20°C designed for 12+ years

EAN: 4260123690038

## Dimensions

### T6 Terminal

Unit: mm [inches]  
± 0.16 [0.0063]

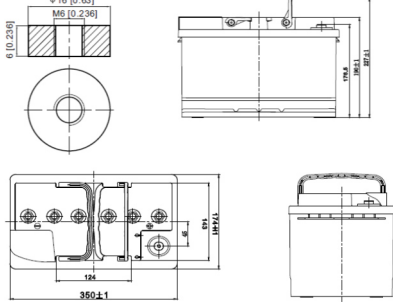

## Temperature Effects in Relation to Battery Capacity

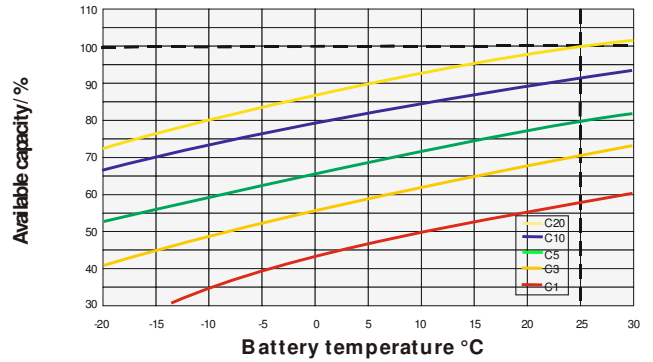

## Specifications

Nominal Voltage		12V
Capacity (25°C)		C100: 90Ah (1,80V/cell) C20: 77.6Ah (1,70V/cell) C10: 71.4Ah (1,70V/cell) C5: 62Ah (1,70V/cell)
Dimensions	Length	350mm (13.8inch)
	Width	174mm (6.85inch)
	Height	190mm (7.48inch)
	Total Height	190mm (7.48inch)
Approx. Weight		24.3kg (53.6lbs)
Maximum charging current		22.5A
Maximum discharge current		700A (5sec.)
Internal resistance		Approx. 6.4mΩ
Capacity affected by temperature (20hr)	40°C	103%
	25°C	100%
	0°C	86%
	-15°C	65%
Self-discharge (25°C)	3 month	Remaining Capacity: 91%
	6 month	Remaining Capacity: 82%
	12 month	Remaining Capacity: 65%
Nominal operating temperature		25°C ±3°C (77°F±5°F)
Operating temperature range		-20°C ~ 55°C (-4°F ~ 131°F)
Float charging voltage (25°C)		13.65 to 13.80V
Cyclic charging voltage (25°C)		14.40 to 15.00V
Terminal material		Copper

## Float Charging Characteristics

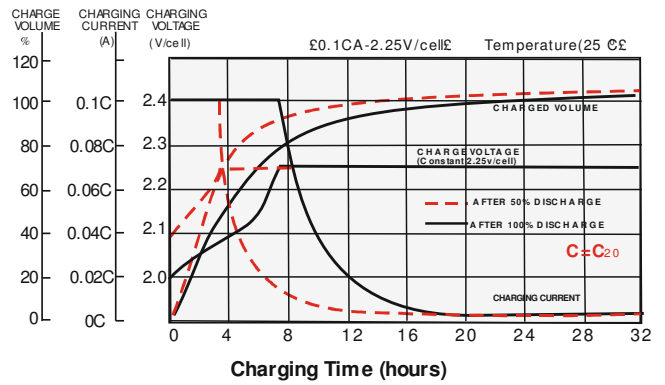

## Cycle Life in Relation to Depth of Discharge

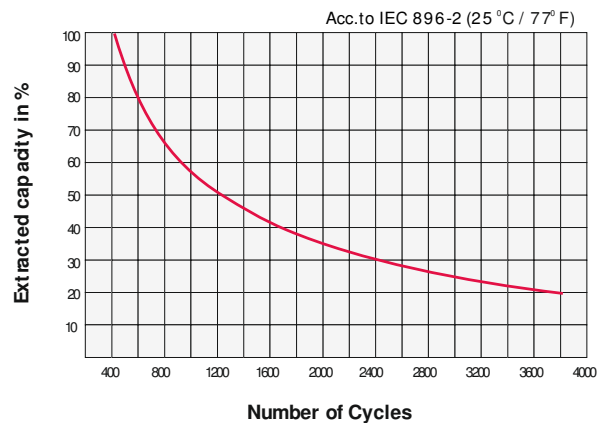

## Constant Current Discharge Characteristics (Ampere / Cell, 25°C)

F.V./TIME	20min	30min	45min	1h	2h	3h	4h	5h	6h	7h	8h	9h	10h	20h	50h	100h
1.60V/cell	99,2	72,9	53,5	43,8	26,1	19,5	15,5	13,1	11,1	9,75	8,72	7,97	7,36	3,96	1,74	0,950
1.70V/cell	88,0	65,6	48,1	39,8	24,5	18,1	14,6	12,4	10,7	9,41	8,44	7,70	7,14	3,88	1,71	0,931
1.80V/cell	72,6	55,6	41,9	35,1	21,9	16,5	13,5	11,6	10,0	8,80	7,94	7,29	6,84	3,75	1,65	0,900

## Constant Power Discharge Characteristics (Watt / Cell, 25°C)

F.V./TIME	20min	30min	45min	1h	2h	3h	4h	5h	6h	7h	8h	9h	10h	20h	50h	100h
1.60V/cell	179,3	134,0	100,1	83,0	50,0	37,4	30,1	25,3	21,6	19,1	17,1	15,8	14,6	7,88	3,47	1,891
1.70V/cell	162,5	122,9	91,3	76,2	47,4	35,3	28,5	24,2	21,0	18,5	16,7	15,3	14,1	7,70	3,39	1,848
1.80V/cell	137,3	106,3	80,7	68,0	42,4	32,1	26,5	22,7	19,7	17,4	15,8	14,5	13,6	7,48	3,29	1,795