

# GELOGiV12700L (12V 70Ah GEL Battery)

Floating Life at 20°C designed for 12+ years

EAN: 4260123683351

## Dimensions

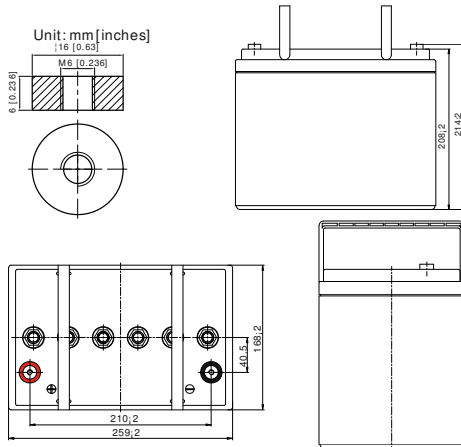

## Temperature Effects in Relation to Battery Capacity

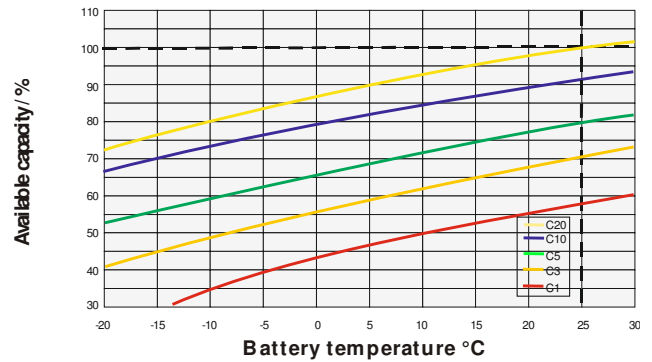

## Specifications

Nominal Voltage	12V	
Capacity (25°C@1.8V/C)	C20: 70Ah C5: 54Ah	
Dimensions	Length	259mm (10.2inch)
	Width	168mm (6.61inch)
	Height	208mm (8.19inch)
	Total Height	214mm (8.43inch)
Approx. Weight	23.0kg (50.7lbs)	
Maximum charging current	21.0A	
Maximum discharge current	700A (5sec.)	
Internal resistance	Approx. 6.4mΩ	
Capacity affected by temperature (20hr)	40°C	103%
	25°C	100%
	0°C	86%
	-15°C	65%
Self-discharge (25°C)	3 month	Remaining Capacity: 91%
	6 month	Remaining Capacity: 82%
	12 month	Remaining Capacity: 65%
Nominal operating temperature	25°C ±3°C (77°F±5°F)	
Operating temperature range	-20°C ~ 55°C (-4°F ~ 131°F)	
Float charging voltage (25°C)	13.65 to 13.80V	
Cyclic charging voltage (25°C)	14.40 to 15.00V	
Terminal material	Copper	

## Float Charging Characteristics

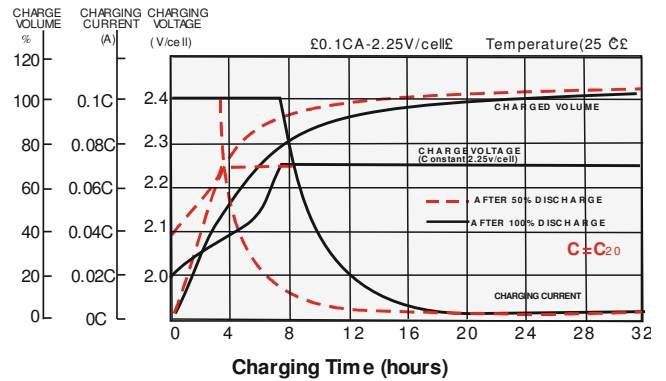

## Cycle Life in Relation to Depth of Discharge

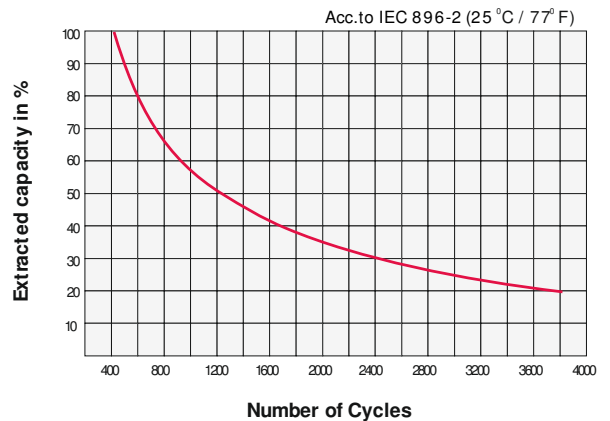

## Constant Current Discharge Characteristics (Ampere / Cell, 25°C)

F.V/TIME	20min	30min	45min	1h	3h	5h	8h	10h	20h
1.60V/cell	92,6	68,0	49,9	40,9	18,2	12,2	8,14	6,87	3,70
1.70V/cell	82,1	61,2	44,9	37,1	16,9	11,6	7,88	6,66	3,62
1.80V/cell	67,8	51,9	39,1	32,8	15,4	10,8	7,41	6,38	3,50

## Constant Power Discharge Characteristics (Watt / Cell, 25°C)

F.V/TIME	20min	30min	45min	1h	3h	5h	8h	10h	20h
1.60V/cell	167,3	125,1	93,4	77,5	34,9	23,6	16,0	13,6	7,35
1.70V/cell	151,7	114,7	85,2	71,1	32,9	22,6	15,6	13,2	7,19
1.80V/cell	128,1	99,2	75,3	63,5	30,0	21,2	14,7	12,7	6,98