

# GELOGiV12600L (12V 60Ah GEL Battery)

Floating Life at 20°C designed for 12+ years

EAN: 4260123683337

## Dimensions

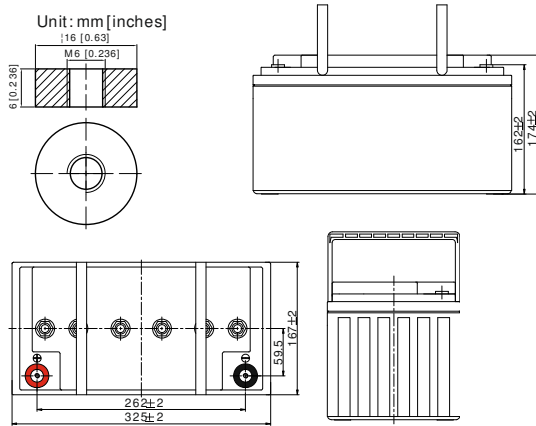

## Temperature Effects in Relation to Battery Capacity

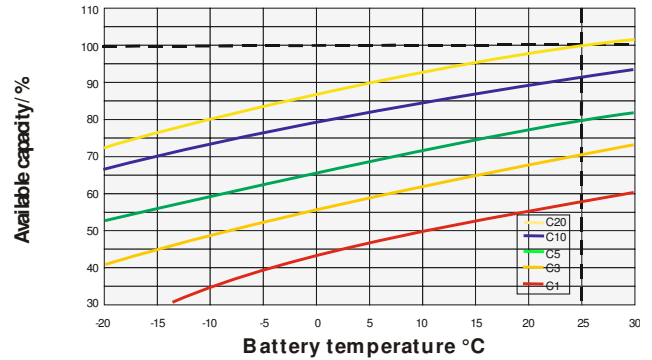

## Specifications

Nominal Voltage	12V	
Capacity (25°C@1.8V/C)	C20: 60Ah	
	C5: 46.2Ah	
Dimensions	Length	325mm (12.8inch)
	Width	167mm (6.57inch)
	Height	174mm (6.85inch)
	Total Height	174mm (6.85inch)
Approx. Weight	21.5kg (47.4lbs)	
Maximum charging current	18.0A	
Maximum discharge current	600A (5sec.)	
Internal resistance	Approx. 8.2mΩ	
Capacity affected by temperature (20hr)	40°C	103%
	25°C	100%
	0°C	86%
	-15°C	65%
Self-discharge (25°C)	3 month	Remaining Capacity: 91%
	6 month	Remaining Capacity: 82%
	12 month	Remaining Capacity: 65%
Nominal operating temperature	25°C ±3°C (77°F±5°F)	
Operating temperature range	-20°C ~ 55°C (-4°F ~ 131°F)	
Float charging voltage (25°C)	13.65 to 13.80V	
Cyclic charging voltage (25°C)	14.40 to 15.00V	
Terminal material	Copper	

## Float Charging Characteristics

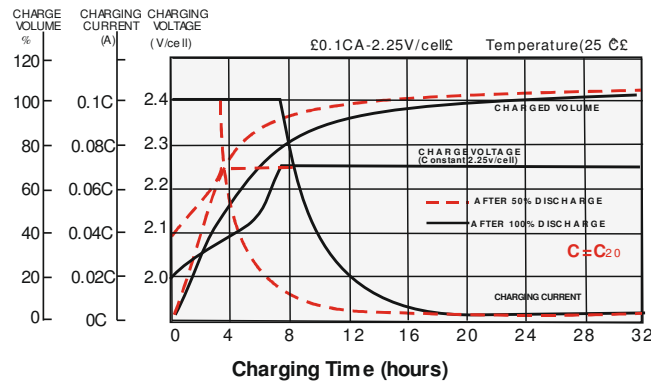

## Cycle Life in Relation to Depth of Discharge

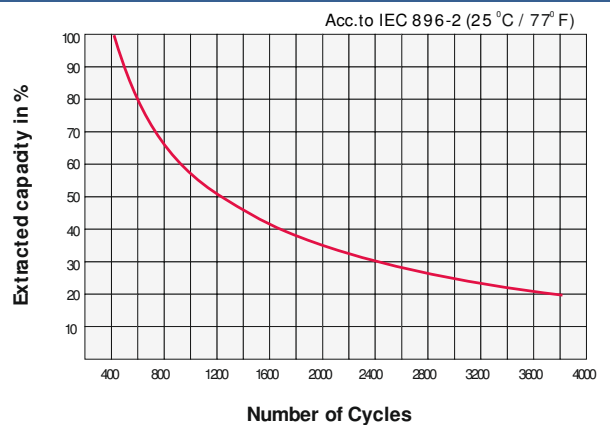

## Constant Current Discharge Characteristics (Ampere / Cell, 25°C)

F.V/TIME	20min	30min	45min	1h	3h	5h	8h	10h	20h
1.60V/cell	79,4	58,3	42,8	35,0	15,6	10,4	6,98	5,89	3,17
1.70V/cell	70,4	52,4	38,5	31,8	14,5	9,90	6,75	5,71	3,10
1.80V/cell	58,1	44,5	33,5	28,1	13,2	9,24	6,35	5,47	3,00

## Constant Power Discharge Characteristics (Watt / Cell, 25°C)

F.V/TIME	20min	30min	45min	1h	3h	5h	8h	10h	20h
1.60V/cell	143,4	107,2	80,0	66,4	30,0	20,3	13,7	11,7	6,30
1.70V/cell	130,1	98,3	73,0	60,9	28,2	19,4	13,3	11,3	6,16
1.80V/cell	109,8	85,0	64,5	54,4	25,7	18,2	12,6	10,9	5,98

Valid from 12-2014