

GELOGiV12380L (12V 38Ah GEL Battery)

Floating Life at 20°C designed for 12+ years

EAN: 4260123683313

Dimensions

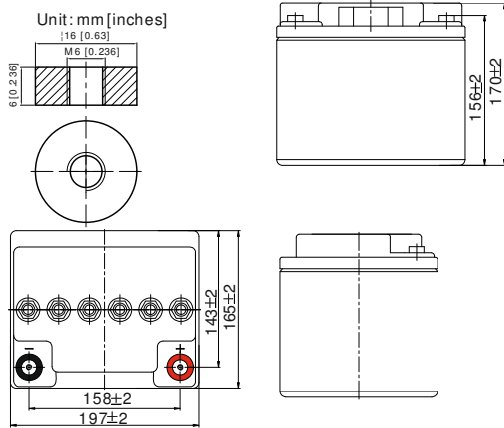

Temperature Effects in Relation to Battery Capacity

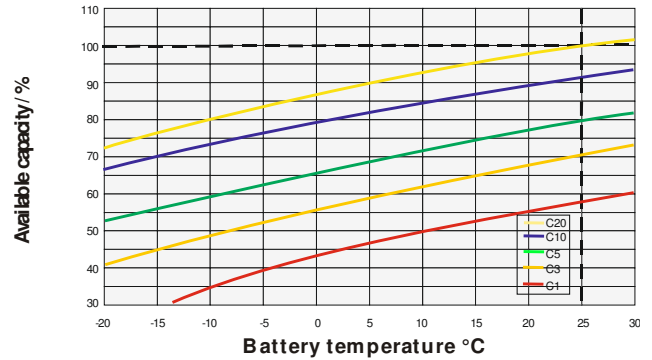

Specifications

Nominal Voltage	12V	
Capacity (25°C@1.8V/C)	C20: 38Ah	
	C5: 29.25Ah	
Dimensions	Length	197mm (7.76inch)
	Width	165mm (6.50inch)
	Height	170mm (6.69inch)
	Total Height	170mm (6.69inch)
Approx. Weight	13.7kg (30.2lbs)	
Maximum charging current	11.4A	
Maximum discharge current	380A (5sec.)	
Internal resistance	Approx. 10.5mΩ	
Capacity affected by temperature (20hr)	40°C	103%
	25°C	100%
	0°C	86%
	-15°C	65%
Self-discharge (25°C)	3 month	Remaining Capacity: 91%
	6 month	Remaining Capacity: 82%
	12 month	Remaining Capacity: 65%
Nominal operating temperature	25°C ±3°C (77°F±5°F)	
Operating temperature range	-20°C ~ 55°C (-4°F ~ 131°F)	
Float charging voltage (25°C)	13.65 to 13.80V	
Cyclic charging voltage (25°C)	14.40 to 15.00V	
Terminal material	Copper	

Float Charging Characteristics

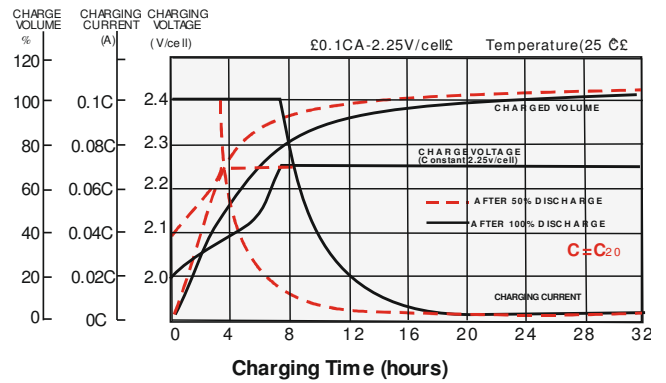

Cycle Life in Relation to Depth of Discharge

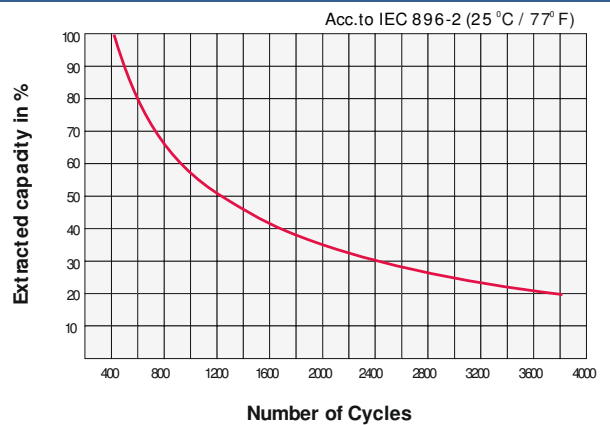

Constant Current Discharge Characteristics (Ampere / Cell, 25°C)

F.V/TIME	20min	30min	45min	1h	3h	5h	8h	10h	20h
1.60V/cell	50,3	36,9	27,1	22,2	9,85	6,60	4,42	3,73	2,01
1.70V/cell	44,6	33,2	24,4	20,1	9,18	6,27	4,28	3,62	1,96
1.80V/cell	36,8	28,2	21,2	17,8	8,35	5,85	4,02	3,47	1,90

Constant Power Discharge Characteristics (Watt / Cell, 25°C)

F.V/TIME	20min	30min	45min	1h	3h	5h	8h	10h	20h
1.60V/cell	90,8	67,9	50,7	42,1	19,0	12,8	8,69	7,39	3,99
1.70V/cell	82,4	62,3	46,2	38,6	17,8	12,3	8,45	7,18	3,90
1.80V/cell	69,6	53,8	40,9	34,4	16,3	11,5	7,98	6,90	3,79