

# GELOGiV12300L (12V 30Ah GEL Battery)

Floating Life at 20°C designed for 12+ years

EAN: 4260123683306

## Dimensions

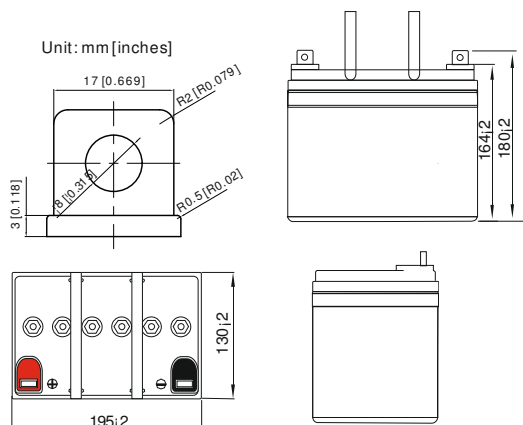

## Temperature Effects in Relation to Battery Capacity

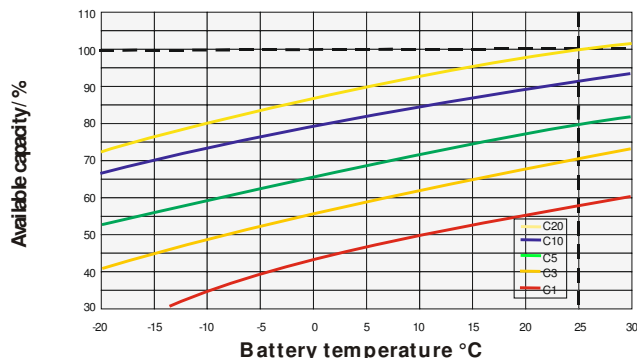

## Specifications

Nominal Voltage		12V
Capacity (25°C@1.8V/C)		C20: 30Ah C5: 23.1Ah
Dimensions	Length	195mm (7.68inch)
	Width	130mm (5.12inch)
	Height	164mm (6.46inch)
	Total Height	180mm (7.09inch)
Approx. Weight		10.65kg (23.48lbs)
Maximum charging current		9.0A
Maximum discharge current		300A (5sec.)
Internal resistance		Approx. 14.6mΩ
Capacity affected by temperature (20hr)	40°C	103%
	25°C	100%
	0°C	86%
	-15°C	65%
Self-discharge (25°C)	3 month	Remaining Capacity: 91%
	6 month	Remaining Capacity: 82%
	12 month	Remaining Capacity: 65%
Nominal operating temperature		25°C ±3°C (77°F±5°F)
Operating temperature range		-20°C ~ 55°C (-4°F ~ 131°F)
Float charging voltage (25°C)		13.65 to 13.80V
Cyclic charging voltage (25°C)		14.40 to 15.00V
Terminal material		Copper

## Float Charging Characteristics

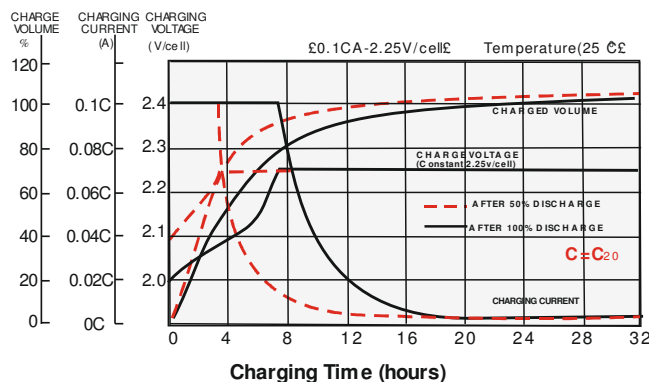

## Cycle Life in Relation to Depth of Discharge

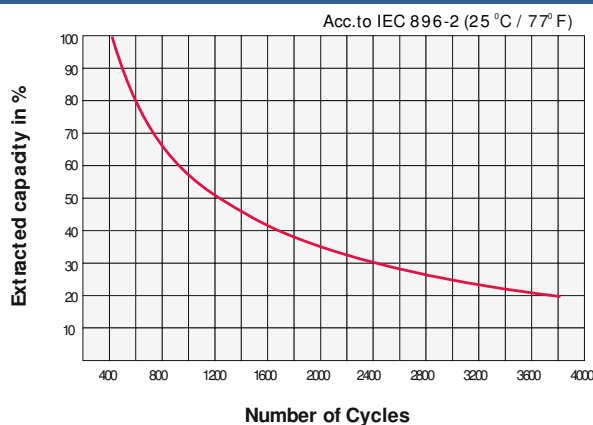

## Constant Current Discharge Characteristics (Ampere / Cell, 25°C)

F.V/TIME	20min	30min	45min	1h	3h	5h	8h	10h	20h
1.60V/cell	39,7	29,2	21,4	18,2	7,78	5,21	3,49	2,85	1,59
1.70V/cell	35,2	26,2	19,2	16,5	7,25	4,95	3,38	2,76	1,55
1.80V/cell	29,1	22,3	16,8	14,6	6,59	4,62	3,18	2,65	1,50

## Constant Power Discharge Characteristics (Watt / Cell, 25°C)

F.V/TIME	20min	30min	45min	1h	3h	5h	8h	10h	20h
1.60V/cell	71,7	53,6	40,0	34,4	15,0	10,1	6,86	5,64	3,15
1.70V/cell	65,0	49,2	36,5	31,6	14,1	9,68	6,67	5,49	3,08
1.80V/cell	54,9	42,5	32,3	28,2	12,9	9,09	6,30	5,27	2,99

Valid from 12-2014