

Toma de fuerza a Motor Engine PTO's

código code

081903

PTO MAN ENGINE D20

Adaptador (Posterior)
Adapter (Rear)

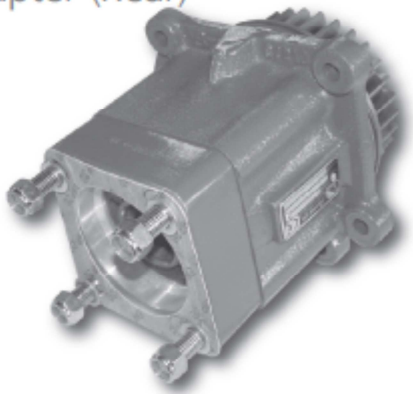

Descripción Description

Toma de fuerza directo a motor, montaje en el registro frontal de 5 taladros. Concebido para trabajo continuo con bombas ISO 4 taladros.

Engine PTO, direct mounting on the 5 bolts-windows of the engine. Designed for continuous working with ISO 4 bolts pumps.

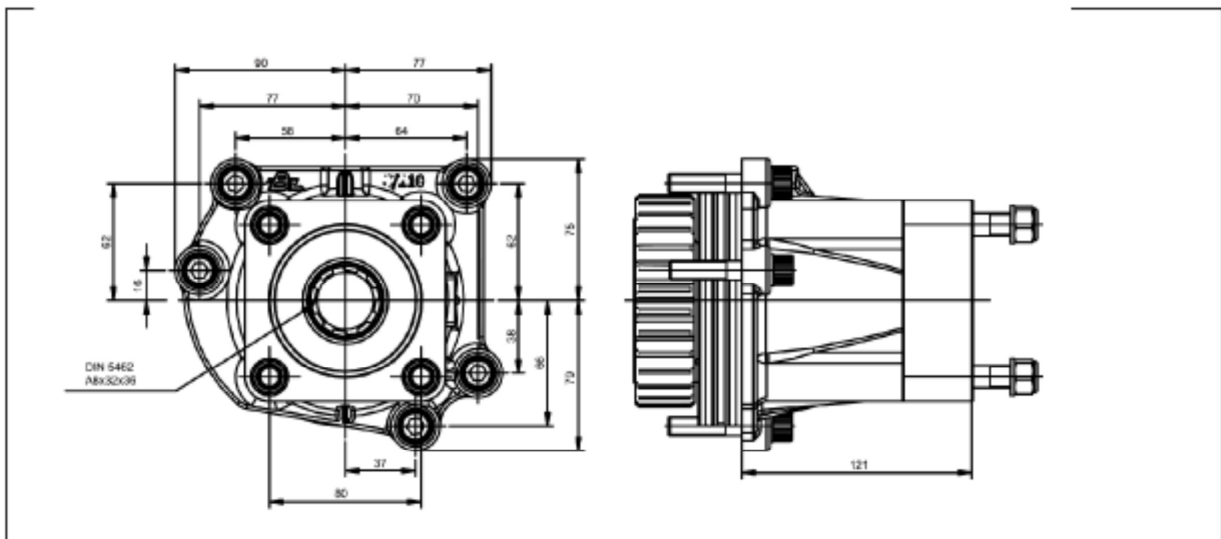

Datos Principales Main Data

Par nominal Torque (Nm)	Continuo Continuous	400
	Intermitente Intermittent	570
Peso Weight (Kg)		11
Potencia 1000 r.p.m. Power 1000 r.p.m.		57 C.V. // 43 Kw
Lado de montaje Mounting position		Posterior Rear
Sentido de giro de la bomba Pump rotation		Derecho Right Hand
Relación motor-bomba Engine to pto ratio		1: 1.233