

**POMPE A PISTONI  
AD ASSE INCLINATO**  
**BENT AXIS PISTON PUMPS**

**CODICE FAMIGLIA**  
FAMILY CODE **108-015**

**"HDS" ISO 12-17-25-34**



Fluido idraulico Fluid	Minerale o sintetico compatibile con guarnizioni: Mineral or synthetic compatible with the following seals: FKM, FPM, HNBR				
Viscosità cinematica consigliata Kinematic viscosity suggested	T media ambiente (°C) Average ambient temp. (°C)	< -40	-40 ÷ 10	10 ÷ 35	> 35
	VG (cSt = mm <sup>2</sup> /s)	16	22	32	46
Viscosità cinematica ottimale di esercizio Optimale kinematic viscosity		VG = 10 cSt ÷ 100 cSt			
Viscosità cinematica max consentita all'avviamento Max kinematic viscosity suggested at the start-up		VG = 750 cSt			
Indice di viscosità consigliato Viscosity index suggested	VI > 100	Temperatura di esercizio Working temperature -40°C ÷ 140°C			
Grado di filtrazione Oil filtering		> 200 bar: 10 µm < 200 bar: 25 µm			
Pres. di aspirazione Inlet pressure		0,85 ÷ 2 bar assoluti/absolut			
Senso di rotazione Pump rotation		Unidirezionale (Dx o Sx) Unidirectional (Right or Left)			

Verificare che la pompa sia posizionata almeno 100 mm sotto il livello minimo del serbatoio olio. Prima di avviare la pompa effettuare spurgo aria.  
Verify that pump is, at least, 100 mm under the minimum level of the tank. Before starting the pump bleed the air.

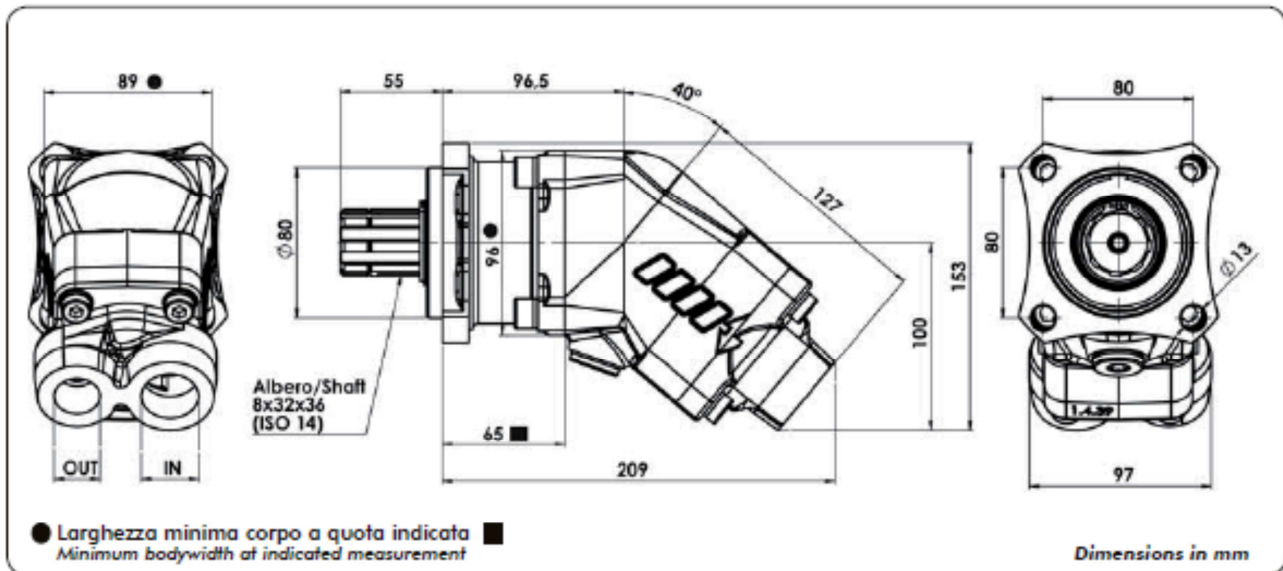

Tipo pompa Pump type	Rotazione Rotation		IN	OUT	IN	OUT
	Destra Right	Sinistra Left				
HDS-12	108-015-01236	108-015-01245	ISO 228 G 1	ISO 228 G 3/4	SAE	SAE
HDS-17	108-015-01736	108-015-01745	G 1	G 3/4		
HDS-25	108-015-02539	108-015-02548	G 1	G 3/4		
HDS-34	108-015-03430	108-015-03449	G 1	G 3/4		

**HDS** 12-17-25-34 **POMPE A PISTONI AD ASSE INCLINATO** 108-015  
**BENT AXIS PISTON PUMPS**

CARATTERISTICHE TECNICHE DI FUNZIONAMENTO / TECHNICAL FEATURES								
Tipo pompa Pump type	Cilindrata Displacement cm <sup>3</sup> /rev	Pressione Pressure		Velocità / Speed			Velocità min. Min. speed rpm	Peso Weight kg
		P1 bar	P3 bar	V0 rpm	V1 rpm	V2 rpm		
HDS-12	12.62	350	400	3000	2300	3000	300	8,7
HDS-17	16.98							
HDS-25	25.12							
HDS-34	33.80							

P1=Pressione massima continua Max. continuous pressure (100%)  
P3=Pressione massima di punta Max. peak pressure (6 sec.max)

V0=Massima continua vuota Max. continuous speed without load  
V1=Massima continua Max. continuous speed  
V2=Massima intermittente Max. intermittent speed

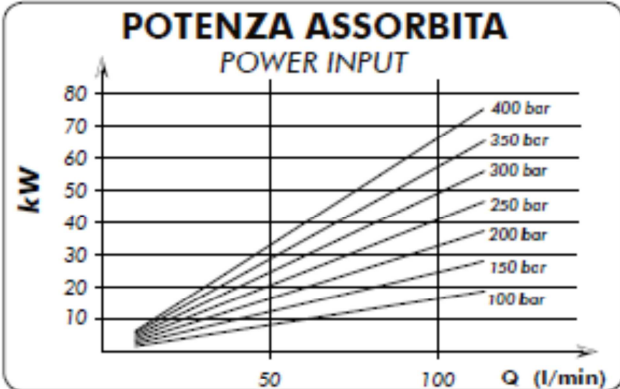
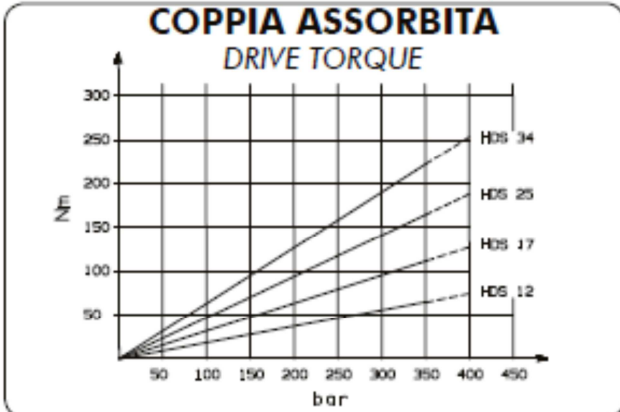
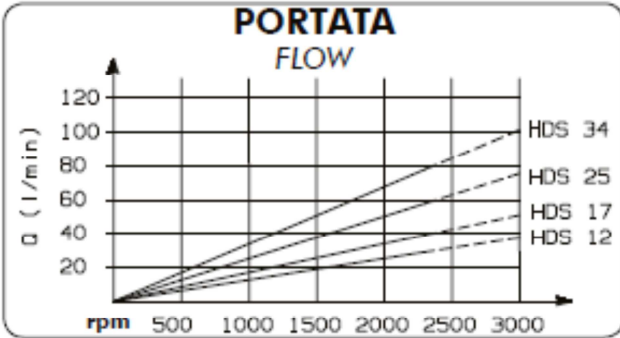

**SCELTA DEL TUBO DI ASPIRAZIONE**  
**HOW TO CHOOSE THE SUCTION PIPE SIZE**

Q Portata Flow l/min	∅ interno min. tubo Min pipe diam. mm	inch	Velocità flusso Flow speed (m/s)
20	25	1"	0,68
30	32	1" 1/4	0,62
40	32	1" 1/4	0,83
50	38	1" 1/2	0,74
60	38	1" 1/2	0,88
70	40	1" 9/16	0,93
80	45	1" 3/4	0,84
90	45	1" 3/4	0,94
100	50	2"	0,85
110	50	2"	0,93
120	60	2" 3/8	0,71
130	60		0,77
140	60		0,83
150	60		0,88
160	63	2" 1/2	0,86
170	63		0,91
180	63		0,96

Per garantire corrette condizioni di aspirazione la velocità del flusso non deve superare 1 m/sec.  
To ensure the proper suction pipe size the flow speed should not exceed 1m/sec.

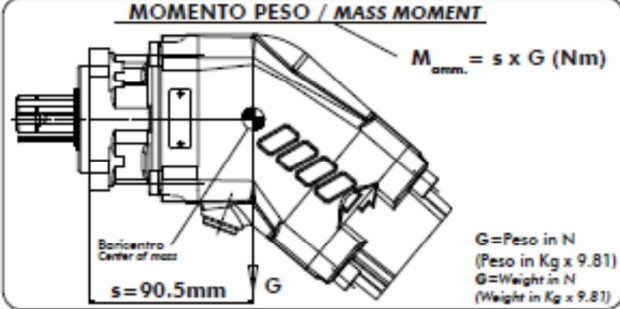

**Kit guarnizioni / Seal Kit**  
108-903-25340