



DEUTSCH
INDUSTRIAL



HD10 Series Technical Manual

A STEP AHEAD



Table of Contents

Introduction	2, 3
Features & Benefits	3
General Performance Specifications	4
Ordering Information	4
Environmental Material Specifications	4
Insert Arrangements	5
Contacts & Application Data	6
Sealing Plug & Removal Tools	7
Protective Caps & Back Shells	7

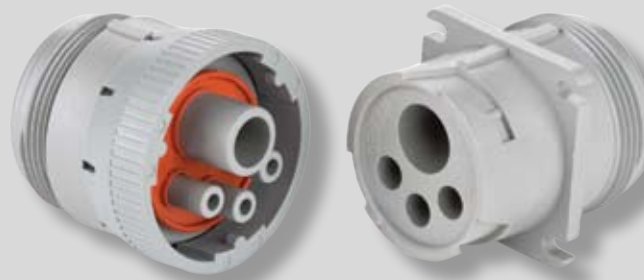

Deutsch is the Difference

Deutsch is well known for its high performance connectors. It has built a solid reputation in the world-wide heavy-duty vehicle market. The need for rugged critical circuit interconnections is now growing as our customers keep pace with evolving advances in electronics technology. Deutsch Industrial is ready to meet this demand for sophisticated custom interfaces.

With a rich company applications heritage, Deutsch Industrial draws on thousands of critical circuit designs for subsystems and assemblies in:

- Engine controllers
- Trucks and buses
- Heavy equipment and farm machinery
- Offroad, marine and recreational vehicles
- Plant equipment and robotics
- Communication systems

Deutsch Industrial provides in-house services: engineering, materials research, prototypes, testing, tooling, dedicated assembly lines and more. When it comes to new product designs or updating mature ones or process optimization, Deutsch expertise and value makes the difference.

Designed to Decrease Costs and Up-Grade Performance

The Deutsch HD10 Series is designed to provide a solution to today's interconnection problems found in the heavy duty industry. The HD10 is a thermoplastic cylindrical connector utilizing crimp type contacts that are quickly and easily inserted and removed. The HD10 Series eliminates problems associated with assembly and maintenance time and is designed for long service life. For an upgrade in performance, specify the HD 10 Series and downgrade your total installed costs.





HD10 Features and Benefits

Shell Styles and Configurations

Rugged thermoplastic shells are available in non-threaded and threaded (for rear hardware) configurations. Receptacles are tooled in inline or square flange mounting styles. Shell arrangements of 3, 4, 5, 6 and 9 utilizing 4, 12 and 16 size contacts that accept 6, 12, 14, 16, 18 and 20 AWG wire meet most wire-break applications.

Mating Characteristics

A tritam coupling is utilized in the HD 10 design that permits quick mating and unmating. Keying silos are molded in the plug half that ease blind mating problems and provide protection for the socket contacts. Both the plug and receptacles are index keyed for visual alignment before coupling. To mate, simply rotate the plug body until it slips into the receptacle, rotate the coupling ring approximately one-quarter turn until a "click" is heard, and that's it - simple and quick.

Sealed Against Moisture and Contaminants

Unlike other conventional cylindrical plastic multi pin connectors, the Deutsch HD10 Series connector is a completely sealed unit. The rear grommets of the plug and receptacle feature integrated silicone wire seals which automatically seal each wired contact as it is locked into place during installation. There are no extra components to be installed on the contact/wire assembly and no potting needed to achieve sealing. The HD10 connector family was designed to be an environmentally sealed connector assembly, not a redesign from an existing product line. All this means a faster, easier, trouble free assembly. An interfacial seal fabricated from tear resistant high temperature silicone is located in the plug. When mated, the contacts are protected from moisture, sand, dust, lubricating oils, fuel, road salt, hydraulic fluid, grease, mud and other contaminants encountered in heavy-duty operations.



Contact Retention System Decreases Installation Costs and Increases Reliability

The HD10 Series uses either crimp type, solid copper alloy contacts or lower cost stamped and formed contacts for damage-proof performance and continuously high operating current loads without overheating. The contacts are crimp terminated using automatic tooling for production and inexpensive, readily available hand tools for field maintenance. Deutsch termination procedures recommend no soldering after properly crimped contacts are completed. After crimping, these contacts are easily installed by simply pushing the contact into place by hand. Contacts are positively secured by the use of "fingers" in the connector which lock behind the shoulder of the contact preventing accidental dislodging. Although securely locked in place, these contacts can be quickly and easily removed by the use of an inexpensive, non-conductive removal tool. The HD10 contact call outs are the same as used in all Deutsch HD, DRC and DT Series of connector products. When used together, this common contact system slashes inventory costs and reduces the chance of assembly and operator errors caused by the hundreds of different types of terminations and processes used within a single-harness assembly.

A General Purpose, Economical Connector Selection

The Deutsch HD10 Series of interconnections brings to the heavy-duty connector industry a general purpose, environmentally sealed connector that is easy to assemble and meets the demand of total support for advanced electronic equipment technology today and in the future.





General Performance Specifications

Temperature

Operating at temperatures from -55⁰ C to +125⁰ C.

Durability

No electrical or mechanical defects after 100 cycles of engagement or disengagement.

Current Rating (Contact current rating @ 125⁰ C(continuous))

Size 16: 13 amps

Size 12: 25 amps

Size 4: 100 amps

Insulation Resistance

1000 megohms min. at 25⁰ C.

Vibration:

No unlocking or unmating and exhibits no mechanical or physical damage after sinusoidal vibration levels of 20g's at 10 to 2000 Hz in each of the three mutually perpendicular planes. No electrical discontinuities longer than 1 microsecond.

Submersion:

Properly wired and mated connection will withstand immersion under three feet of water without loss of electronic qualities or leakage.

Corrosion Resistance

Connectors show no evidence of corrosion after exposure to 48 hours of salt spray per MIL-STD 1344 method 1001.

Fluid Resistance

Connectors show no damage when exposed to most fluids used in industrial applications.

Dielectric Withstanding Voltage:

Current leakage less than 2 milliamps at 1500 VAC.

Crimp Tensile Strength: (Solid & Stamped)

#16 Size Contacts 25 lbs.

#12 Size Contacts 70 lbs.

#4 Size Contacts 300 lbs.

CONTACT RESISTANCE

CONTACT SIZE	WIRE GAUGE AWG(mm ²)	Test Current (Amps)	Resistance (mV) Solids	Resistance (mV) Stamped & Formed
16	20 (.50)	7.5	60	100
	18 (.80)	10	60	100
	16 (1.0)	13	60	100
12	14 (2.0)	13	60	100
	12 (3.0)	25	60	100
4	6 (13.0)	100	60	N/A

Deutsch HD10 Series Part Numbering System

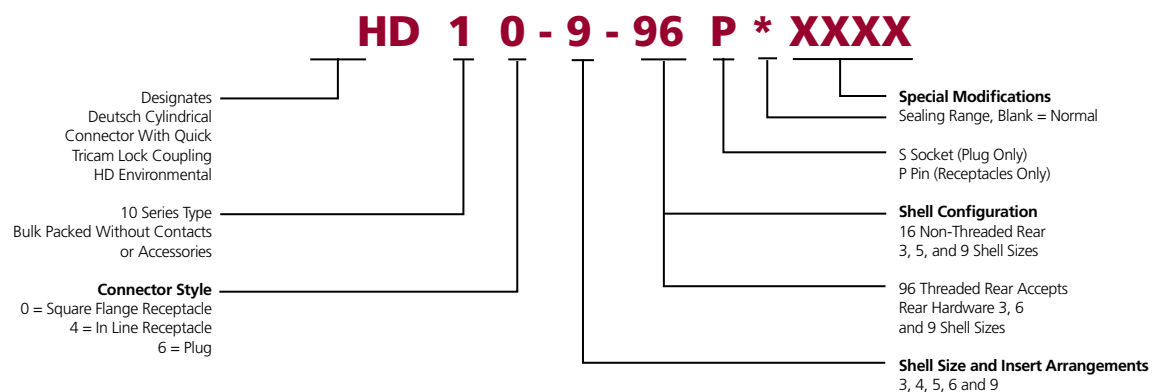

Environmental Material Specifications

Plug:

Shell: Thermoplastic
Insert: Retainer - Thermoplastic
Grommet - Silicone rubber

Receptacle:

Shell: Thermoplastic
Insert: Retainer - Thermoplastic
Grommet and Interfacial Seal - Silicone rubber

Solid Contacts

Pin: Copper Alloy
Socket: Copper Alloy
Finish: Nickel Plating*

Sealing Plugs

Thermoplastic: Size 12 thru 16
Elastomer: Size 4

Stamped & Formed Contact

Pin: Copper Alloy
Socket: Copper Alloy
Finish: Nickel Plating

*Optional: Gold plating (consult factory)



CONTACTS AND APPLICATION DATA

Solid Contacts

SIZE	SOLID CONTACT PART NUMBERS		WIRE SIZE AWG (mm ²)	RECOMMENDED STRIP LENGTH INCHES (mm)	MIN CONTACT RETENTION LBS (N)	REF CRIMP TENSILE LBS (N)	MAX RATED AMPS AT 125°C CONTINUOUS
	PIN	SOCKET					
16	0460-202-16**	0462-201-16**	16-20 (1.0 - 0.50)	.250 - .312 (6.35 - 7.92)	25 (111)	35-20 (156-89)	13
16	0460-215-16**	0462-209-16**	14 (2.0)	.250 - .312 (6.35 - 7.92)	25 (111)	70 (311)	13
12	0460-204-12**	0462-203-12**	12-14 (3.0 - 2.0)	.222 - .284 (5.64 - 7.21)	30 (134)	75-70 (334 - 311)	25
4	0460-204-04**	0462-203-04**	6 (13.0)	.430-.492 (10.92-12.50)	35 (156)	300 (1334)	100

* See Envelope Print 0425-205-0000. Consult factory for alternate finishes.

Solid Contacts

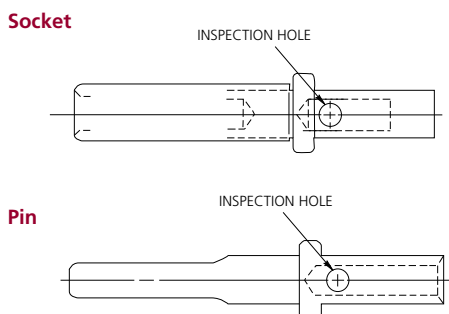

Stamped and Formed Contacts

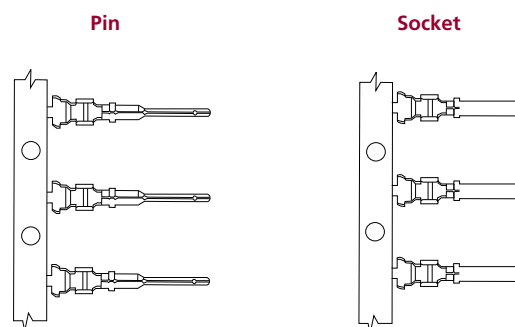

Stamped & Formed Contacts

SIZE	STAMPED & FORMED CONTACT PART NUMBERS		CARRIER STRIP IDENTIFICATION	WIRE SIZE AWG (mm ²)	WIRE INSULATION O.D. RANGE	RECOMMENDED STRIP LENGTH INCHES (mm)	MIN CONT. RETENTION LBS (N)	REF CRIMP TENSILE LBS (N)	MAX RATED AMPS AT 125°C CONTINUOUS
	PIN	SOCKET							
16	1060-14-01**	1062-14-01**	14-16	14 - 18 (2.0 - .75)	.095 - .150 (2.41 - 3.81)	.150 - .200 (3.81 - 5.08)	25 (111)	25 (111)	13
16	1060-14-10**	1062-14-10**	14 -16	14 - 18 (2.0 - .75)	.095 - .150 (2.41 - 3.81)	.150 - .200 (3.81 - 5.08)	25 (111)	25 (111)	13
16	1060-16-01**	1062-16-01**	16 - 18	14 - 18 (2.0 - .75)	.075 - .140 (1.91 - 3.55)	.150 - .200 (3.81 - 5.08)	25 (111)	25 (111)	13
16	1060-16-06**	1062-16-06**	0.5 - 1.0	16 - 20 (1.0 - 0.50)	.055 - .100 (1.40 - 2.54)	.150 - .200 (3.81 - 5.08)	25 (111)	25 - 15 (111 - 67)	13
16	1060-16-07**	1062-16-07**	0.75 - 2.0	14 - 18 (2.0 - .75)	.075 - .140 (1.91 - 3.55)	.150 - .200 (3.81 - 5.08)	25 (111)	25 (111)	13
16	1060-16-09**	1062-16-09**	16 - 18	14 - 18 (2.0 - .75)	.075 - .140 (1.91 - 3.55)	.150 - .200 (3.81 - 5.08)	25 (111)	25 (111)	13
16	1060-16-12**	1062-16-12**	1.0 - 2.5	12 - 16 (2.5 - 1.0)	.075 - .140 (1.91 - 3.55)	.175 - .225 (4.45 - 5.72)	25 (111)	25 (111)	13
16	N/A	1062-16-14**	14 - 16	12 - 16 (2.5 - 1.0)	.075 - .140 (1.91 - 3.55)	.175 - .225 (4.45 - 5.72)	25 (111)	25 (111)	13
12	1060-12-01**	1062-12-01**	12 - 14	12 - 14 (4.0 - 2.0)	.113 - .176 (2.87 - 4.47)	.225 - .275 (5.72 - 6.991)	30 (134)	70 (311)	25
12	1060-12-02**	1062-12-02**	10 - 12	10 - 12 (6.0 - 4.0)	.140 - .204 (3.56 - 5.18)	.225 - .275 (5.72 - 6.99)	30 (134)	70 (311)	25

** For proper dies and stamped & formed crimp dimensions - See Envelope 0425-208-0000 12 Size Consult factory for alternate finishes
 0425-203-0000 16 Size
 0425-059-0000 16,20 Size
 0425-039-0000 16 Size
 0425-041-0000 12 Size



HD10 Series Technical Manual



SEALING PLUG

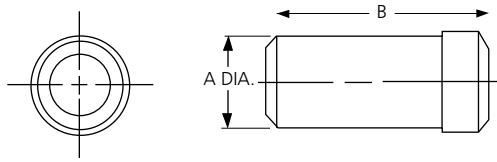

CONTACT REMOVAL TOOL

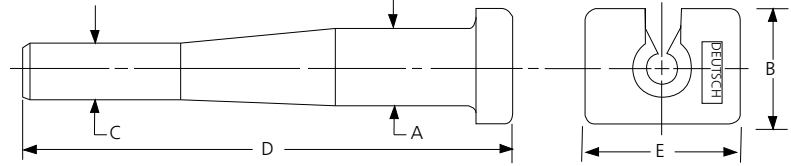

PART #	CONTACT SIZE	A DIA. ±.010	B DIA. ±.030	CONTACT SIZE	WIRE RANGE AWG	PART NUMBER NORMAL SEAL	PART NUMBER REDUCED "E" SEAL	±.015 A	±.031 B	REF. C	REF. D	±.031 E	COLOR
114017	12/16	.121	.575	16	14-20	N/A	0411-336-1605	.286	1.000	.160	2.230	.500	Medium Blue
114019	4	.312	.750	16	14 -20	0411-204-1605	N/A	.286	.500	.160	2.275	1.000	Blue
				12	12-14	N/A	0411-337-1205	.350	1.250	.202	2.230	.625	Orange
				12	12 -14	0411-291-1405	N/A	.286	.500	.180	2.230	.625	Green
				12	12-14	114010	N/A	.350	.625	.202	2.300	1.250	Yellow
				4	6	114009	114009	.740	.875	.435	3.100	1.500	White

HD 10 PROTECTIVE CAPS AND BACK SHELLS

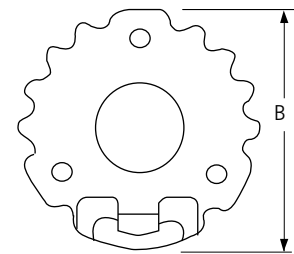
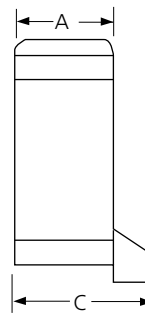
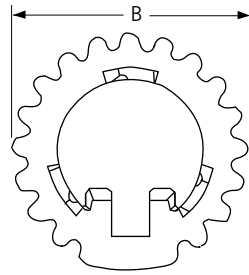
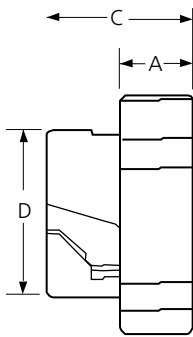

HDC14 PROTECTIVE COVER FOR PLUG

SIZE	±.025 A	±.025 B	±.025 C	±.025 D
HDC14-3	.370	1.221	.750	.863
HDC14-6	.367	1.448	.740	1.123
HDC14-9	.370	1.650	.750	1.279

HDC16 PROTECTIVE COVER FOR RECEPTACLE

SIZE	±.025 A	±.025 B	±.025 C
HDC16-3	.492	1.176	.692
HDC16-5	.492	1.320	.692
HDC16-6	.492	1.443	.692
HDC16-9	.487	1.580	.670

HD18 BACK SHELL

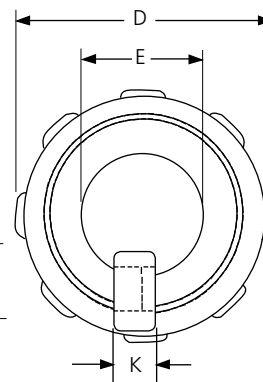
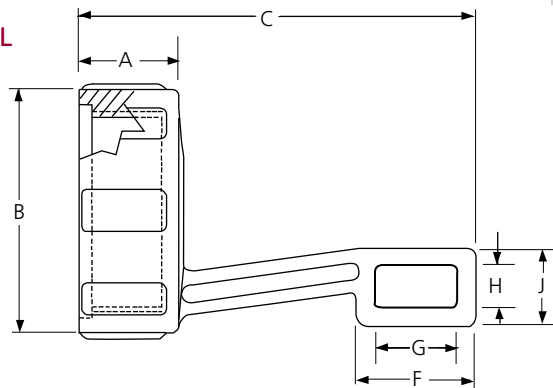

SIZE	±.025 A	±.025 B	±.025 C	±.025 D	±.025 E	±.025 F	±.025 G	±.025 H	±.025 J	±.025 K	THREAD
HD18-003	.465	1.138	1.865	1.188	.577	.560	.400	.200	.360	.200	.9375-20 UNEF-REF
HD18-005	.365	1.281	1.765	1.313	.720	.560	.400	.200	.360	.200	1.0625-18 UNEF-REF
HD18-006	.465	1.513	1.865	1.563	.861	.560	.400	.200	.360	.200	1.3125-18 UNEF-REF
HD18-009	.465	1.570	1.850	1.625	1.000	.560	.400	.200	.360	.200	1.375-18 UNEF-REF

Deutsch Industrial UK
Stanier Road
St. Leonards On Sea
East Sussex TN 38 9RF
England
Ph. 44 (0) 1424 852 722
Fax 44 (0) 1424 855 979
industrialuk@deutsch.net

Deutsch Industrial Europe
Fraunhoferstrasse 11b
82152 Martinsried
Germany
Ph. +49 (0) 89 899157-0
Fax +49 (0) 89 857 4684
info.eu@deutsch.net



Deutsch Industrial US
3850 Industrial Ave.
Hemet, CA 92545
USA
Ph. +1 (951) 765-2250
Fax +1 (951) 765-2255
insidesales-ipd@deutsch.net

Deutsch Industrial Japan
NIHON Deutsch Ltd.
44-10, Ohyamakanai-cho
Itabashi-ku, Tokyo 173-0024
Japan
Ph. + 81-3-5995-5192
Fax + 81-305995-5193
rtakemura@nihon-deutsch.co.jp

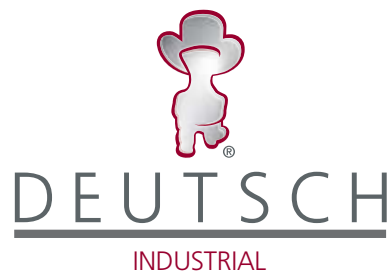

3850 Industrial Avenue, Hemet, California 92545 Tel.: (951) 765-2250 - Fax: (951) 765-2255
Web: www.deutsch.net - Edition 2007

A STEP AHEAD